



DESIGN AND MANUFACTURING OF SELF OPERATING WATER PUMP

Ronak Rana

Assistant Professor,

Department of Mechanical Engineering, Sardar Patel College of Engineering, Bakrol

Walsh Christian

Assistant Professor,

Department of Mechanical Engineering, Sardar Patel College of Engineering, Bakrol

ABSTRACT

This paper explores the development and design of a self-operating water pump, ideal for small-scale irrigation and various household applications. The pump utilizes water's kinetic energy to drive its mechanisms, making it suitable for areas without access to electricity. Key components of the system include blades, chain drive, turbine wheel, and reciprocating pump. The entire system must be constructed near flowing water sources like rivers or canals. Its design allows for easy customization with locally available materials, making it adaptable to community needs. The self-operating nature ensures it works efficiently with any swiftly flowing water body, providing a sustainable solution for water supply and irrigation in off-grid areas.

Keywords: Centrifugal pump, Diffuser, Impeller



INTRODUCTION

Pumps are available in multiple sizes to suit a broad range of uses. Based on their fundamental mode of operation, they can be categorized as either displacement or dynamic pumps. Centrifugal and special effect pumps are two subclasses of dynamic pumps. Pumps used for displacement can be further divided into rotary and reciprocating types. Basically, any of the pump designs can handle any kind of liquid. The centrifugal pump is typically the most cost-effective pump design when compared to rotary and reciprocating pumps. Positive displacement pumps have a tendency to be more efficient than centrifugal pumps, however this advantage is typically outweighed by higher maintenance costs.

Since the majority of electricity used by pumps globally is utilized by centrifugal pumps.

WORKING PRINCIPLE

A positive displacement pump, known as a reciprocating pump, moves fluid by trapping a fixed volume of it and then displacing that trapped volume into the output pipe. The fluid enters the pumping chamber through an inlet valve and is forced out by the diaphragm or piston through an output valve. They can be double acting, with suction and discharge in both directions, or single acting, with independent suction and discharge. The piston advances to the left during the suction stroke, which causes the cylinder to become vacuum. Water enters the cylinder through the suction valve opening as a result of this vacuum. In the delivery stroke, the piston travels in a rightward direction. Water is driven into the delivery pipe when the suction valve closes and the delivery valve opens due to the cylinder's growing pressure. The aircraft is utilized to obtain consistent release. Self-priming reciprocating pumps can handle extremely high heads at low flows.

Their consistent flow rate makes them ideal for metering tasks and ensures dependable discharge flows. The driver's rpm is the only way to modify the flow rate.

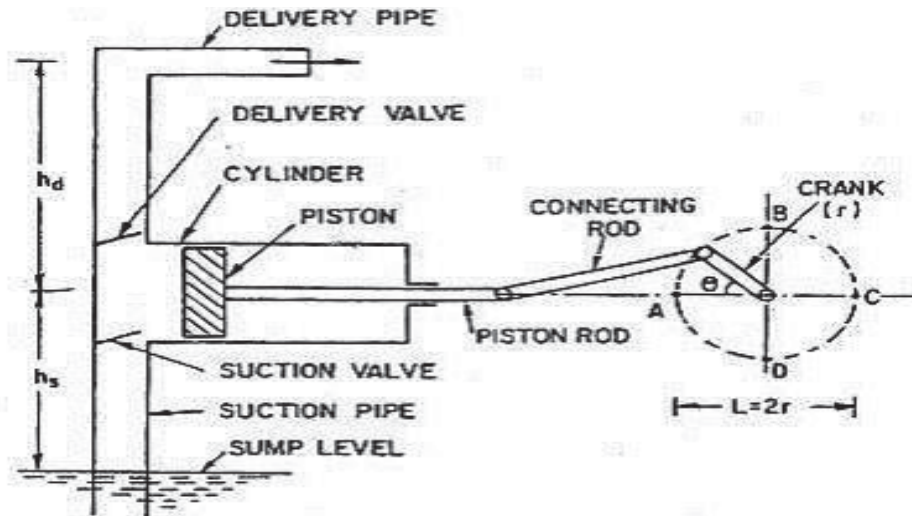

Fig 1. Working Principle of Reciprocating Pump

These pumps produce a strong pulse flow. If constant current is required, the discharge system must have additional functions such as batteries. An automatic pressure relief valve is used on the pressure side of all positive displacement pumps, which is set to a safe pressure. The performance of a pump is described by its net head h , which is defined as the change in Bernoulli height between the suction and delivery sides of the pump. h is expressed as the corresponding height of the water column.

MAJOR COMPONENTS USED IN SELF OPERATING PUMP

- Pulley
- Supporting Frame & Base Frame
- Pelton Wheel
- Shaft
- Rod
- Bearing with Housing
- Square Tubing



- Chain drive
- Nut-Bolt

WORKING/IMPLEMENTATION OF THE PROJECT WORK

As stated above, the model can only be applied in the vicinity of river bodies, because that is the source of all energy, which is hydropower. It can be developed near a waterfall, canal, and river with sufficient flow velocity. The self-acting pump consists of two turbine impellers, both of which are connected to the main shaft and connected to the frame by means of a suitable bearing mechanism. The main shaft consists of a gear and chain mechanism, which is connected to the secondary shaft according to the design. The secondary shaft is connected to the connecting rod of the piston pump. If the model is placed over flowing water, the turbine wheel will be slightly submerged in the water. The turbine wheel turns due to the kinetic energy of the flowing water. The main shaft rotates and the secondary shaft rotates at a higher speed due to the random diameter of the gear. The rod attached to the shaft moves back and forth up and down due to the rotation of the shaft. Thus, a reciprocating pump draws water from the source and delivers the water to its destination.

ADVANTAGES OF A SELF-PRIMING PUMP

- No fuel
- The kinetic energy of the water works, so no external source is needed.
- Low maintenance costs.
- Pollution free.

LIMITATIONS OF THE SELF-PRIMING PUMP

- The pump cannot be installed everywhere
- It cannot be installed near water
- It should only be installed near running water



- Requires high speed flow
- It is a seasonal pump
- Not during the dry season due to the water level in the area.

APPLICATION:

- For use in agriculture
- On the construction site
- Kingfish Target.

PROBLEM SUMMARY

- Water is a vital requirement on a livestock farm and has a significant impact on livestock welfare, productivity and farm profitability.
- In the current system, the main source of irrigation, drinking and other water is groundwater and river water.
- In the old system, to bring water from such water bodies to the required area, Dug wells and necessary channels are made from the river, and a pump is used in case of higher potential height.
- Making canals from the river to the required area is an effective method, but requires a large initial investment if the river is far from the area and also requires a lot of manpower.
- The disadvantage of such a system is that the channel cannot be made higher than the body of the river, the water flows at the same level or lower.
- Another method is to dig a well. Such systems also require a large initial investment, even if the well is dug, but pumps are necessary to remove the water from the area of use of the well.



- A pump is a device used to transport water from one place to another also at different potentials using different energy sources. Like electricity and fuel (diesel/gasoline), which are also expensive.

LITERATURE REVIEW

Stavorsetal[1] evaluates new methods of water-lifting devices. Emphasizing the evolution of actual achievements in water-lifting equipment, significant advances made over hundreds of years are presented and discussed. Important information about old-fashioned water lift inventions with obvious characteristics of strength, flexibility and supportability. A correlation of some important mechanical improvements in early human development is complete. Mogajiet al [2] created an improved pedal water pump. Similar pumps are widely used in various companies. Proper selection of equipment with proper placement was critical to reliable M/C supply and operation. The pump and frame link was also an integral part of the job. The pump cannot be seen disassembled; its cooperation with the frame can also lead to service life and premature disappointment. The development of an improved pedal water pump machine was greeted with the expectation that it would provide a simple, cost-effective answer to the question of how to transport groundwater with a generally lower load. This project will culminate in the development of an improved pedal water pump for use in the provinces. This improvement was due to the need to pump the frame structure, which does not use power as a source of power in the immature region. The body was made of a sensitive pump that was controlled by acceleration. Pedal power was transmitted to the pump via a chain drive. According to the given plan, the diameter of the opening of the pumping chamber is 56 cm and the speed is 60 stroke/minute. The machine was born when 0.02 m³ to 0.06 m³ were fired separately from 20 seconds to 60 seconds as shown in Table 2. As the discharge period increases, the amount of water released also increases. Despite the fact that the frame consumed vitality, acceleration is prescribed to people as a type of activity that consumes calories in the body. Therefore, treadmills and bicycles should be used.

DESIGN DETAILS & ANALYSIS

- We created the working pump design ourselves in a fixed 2D, 3D design frame work, blade, piston pump below.
- This is a 3-dimensional image template.
- This model gives an idea of the exterior and the best 2D design. The model requires a suitable frame to stand on the surface of the water and on the ground.

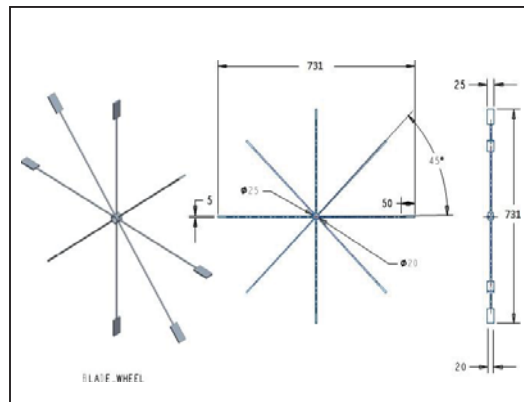
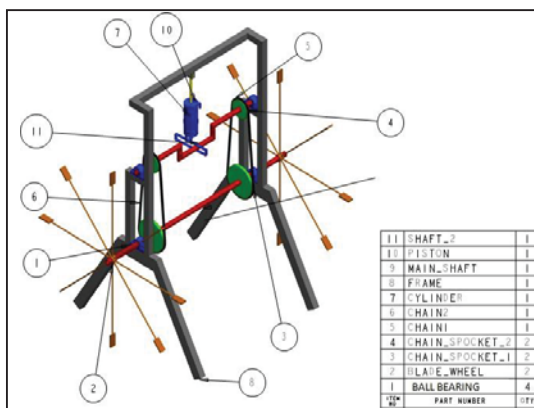

Fig.3.1 3: D Design of frame and blade wheel

Fig.3.1.3: Blade wheel design

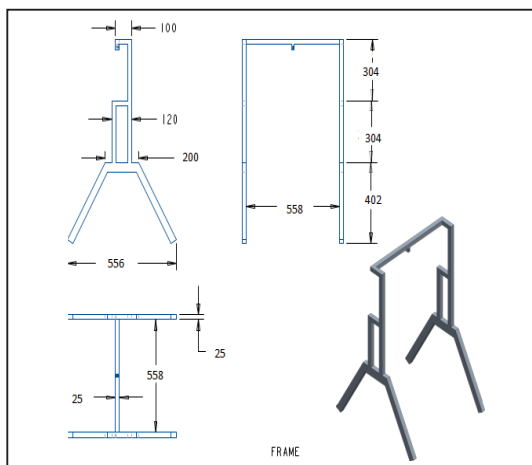

Fig.3.1.1: 2D Design

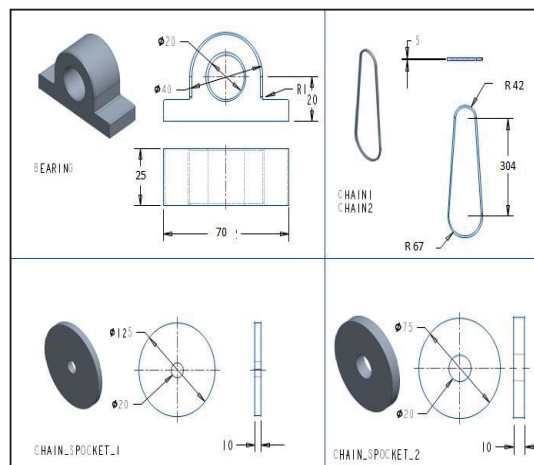

Fig.3.1.4.1: Different Parts Design

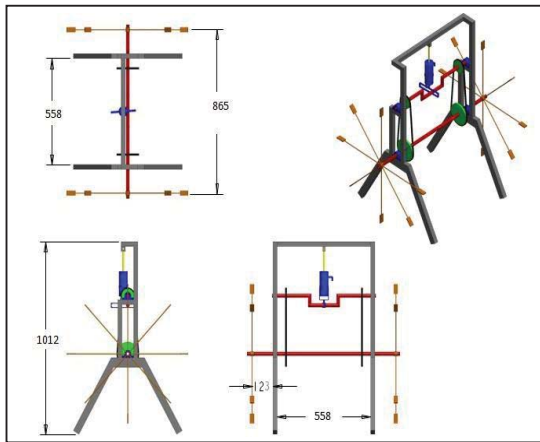

Fig.3.1.2: 2D frame design

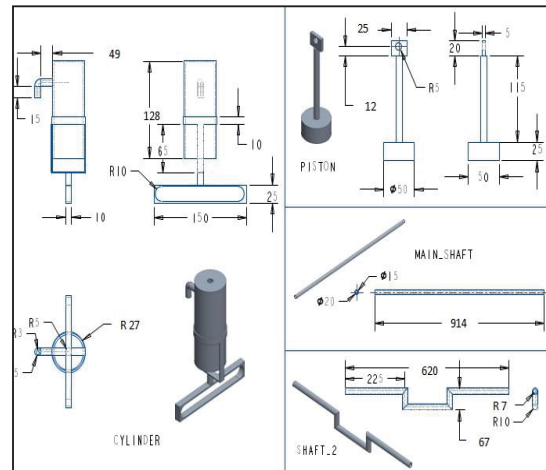

Fig.3.1.4.2: Different Parts Design

This model gives an idea of the exterior and the best 2D design. The model requires a suitable frame to stand on the surface of the water and on the ground.

DESIGN AND CALCULATION

- Calculation for Chain Drive

Transmission ratio = 1:3

$$VR = \frac{N1}{N2} = \frac{T2}{T1}$$

Where,

N1= Speed of smaller sprocket = 3

N2 = Speed of big sprocket = 1

T1 = Number of teeth on smaller

Sprocket = 18



T2=number of teeth on big sprocket =44

- **Calculation of discharge**

$$Q = \underline{A \times L \times N}$$

60

Where

Q = Discharge

A = Area of piston or cylinder

N = R.P.M of crank

- **Area of cylinder**

$$A = \pi/4 \times (D)^2$$

$$= \pi/4 \times (0.12)^2$$

$$= 0.045216 \text{ mm}$$

- **Length of stroke (L)=0.2m**

N=rpm of driven shaft=3

(For 1revolution of driving shaft)

$$(Q_{th}) = 0.045216 \times 0.2 \times 3 / (60)$$

$$= 3.122 \text{ lit/min}$$

ANALYSIS

Analysis of Pump

The Analysis of pump is created in Ansys 2019 software in user define feature problem.

The analysis is based on computational fluid dynamics.

- **Wall-1:- top head surface of piston (non deforming moving wall)**

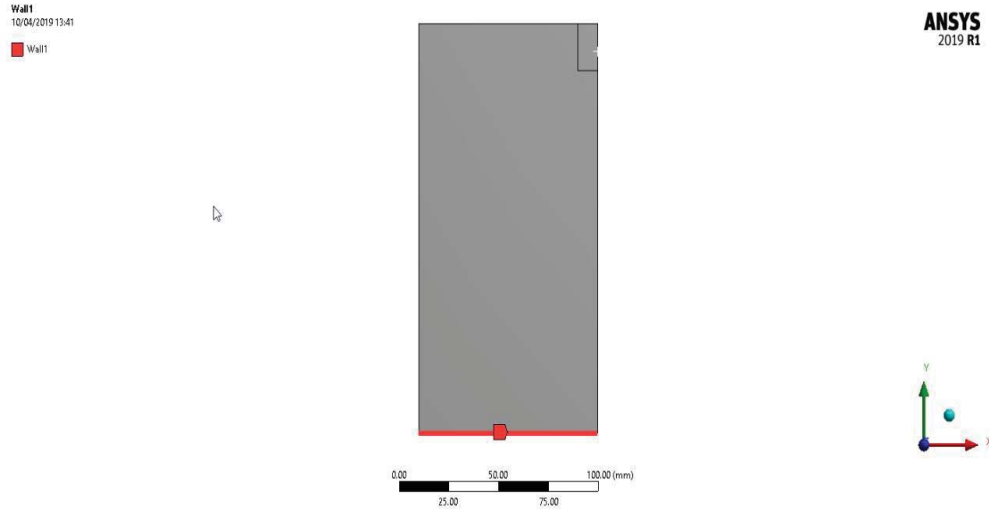

Fig-3.3.1.1 wall-1

- **Wall-2:- Deforming wall**

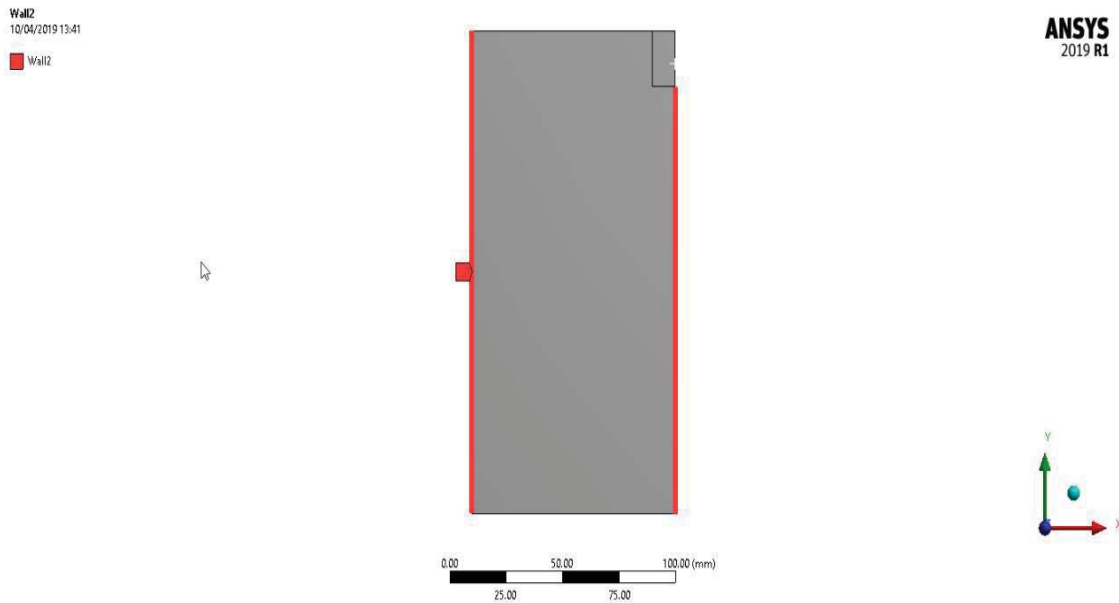

Fig-3.3.1.2 wall-2

- **Fluent setting**

The transient condition is applying for fluent setting. In transient condition the load condition is varies and the timing is steady for analysis

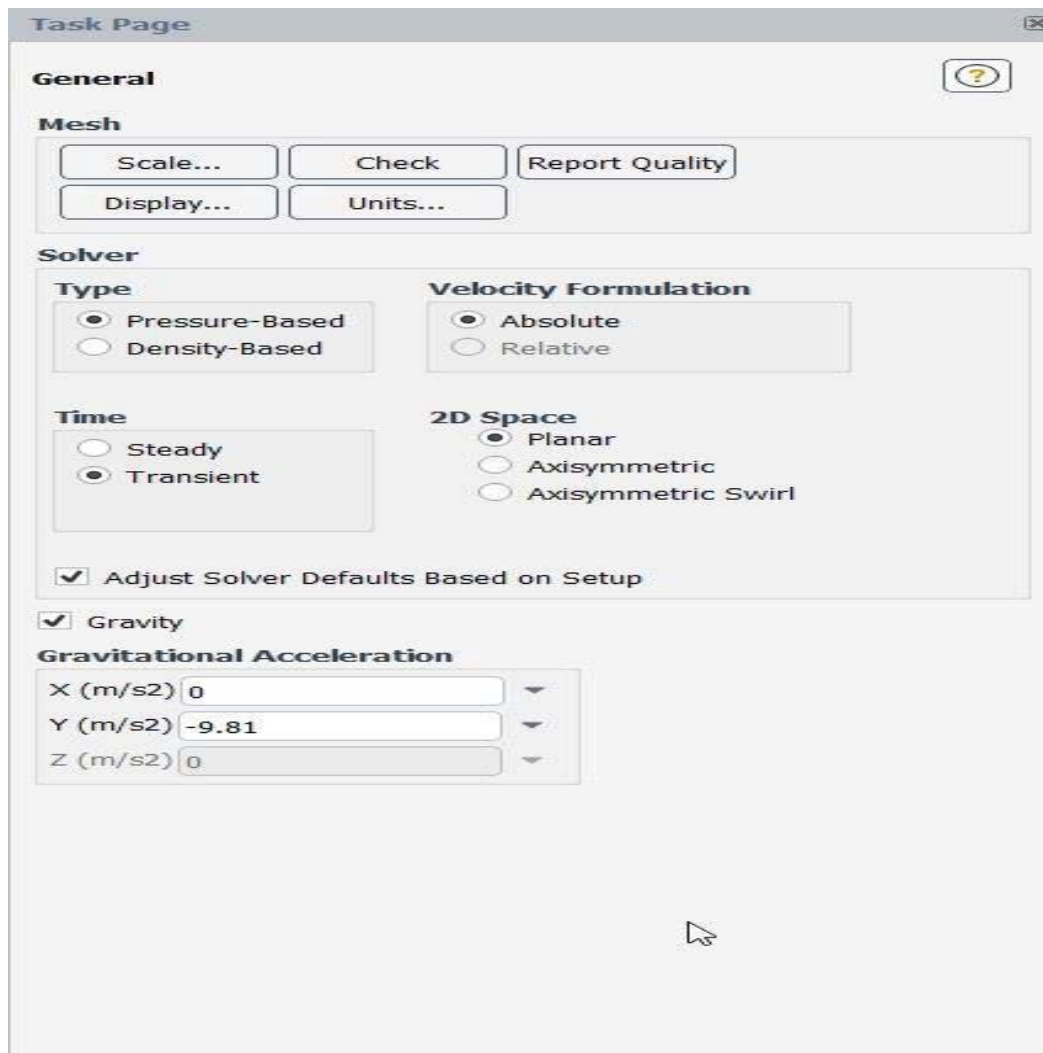

Fig -3.3.1.3 image of fluent setting

- **Viscous model**

The energy equation is kept on for k-epsilon for (turbulent flow).

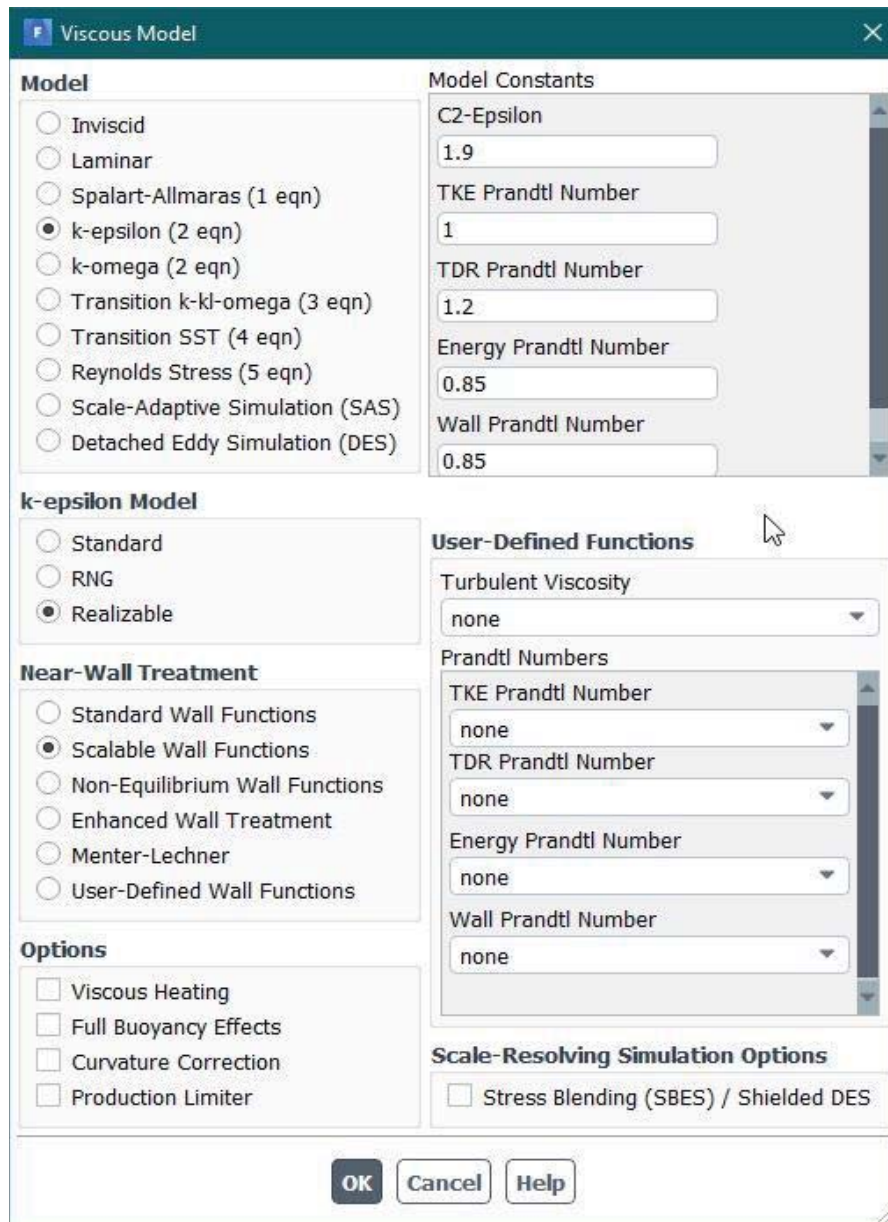

Fig- 3.3.1.4 viscous model

- Dynamic mesh zone

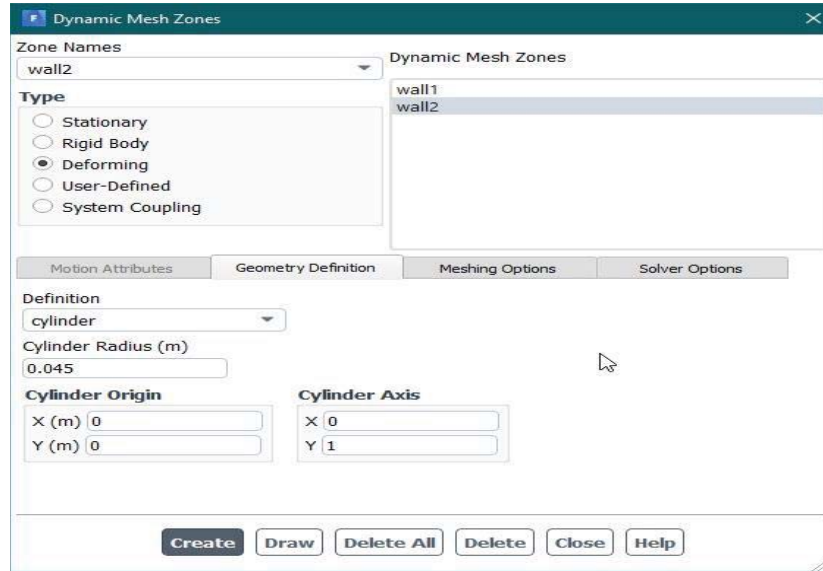

Fig-3.3.1.5 dynamic mesh zone

RESULT ANALYSIS

Result of Velocity

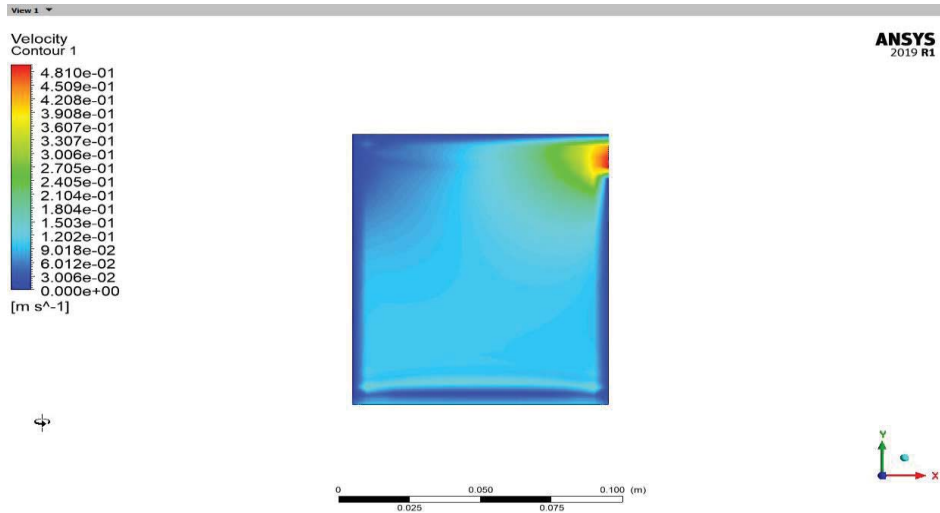

Fig-3.3.2.1.1 Velocity Result

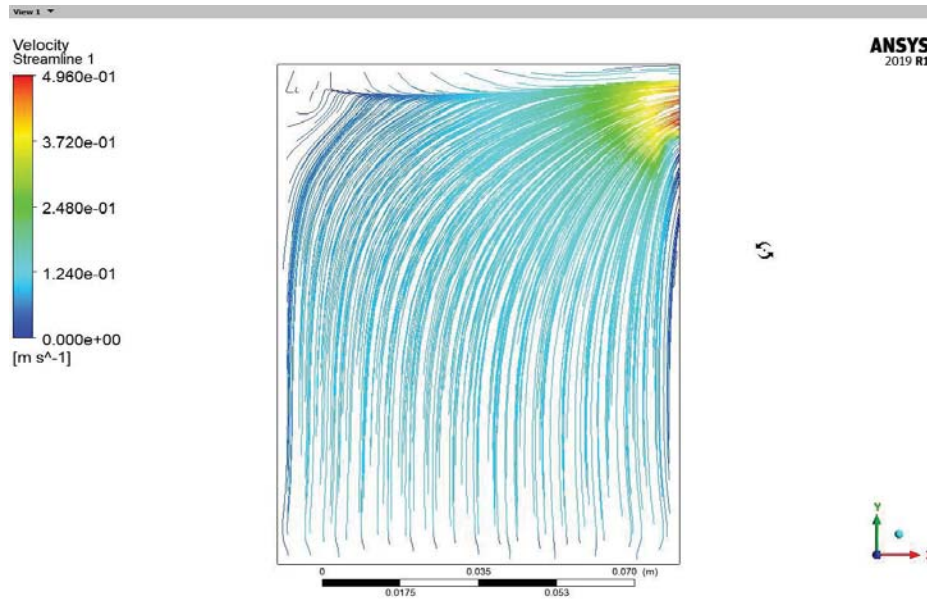

Fig-3.3.2.1.2 Streamline Velocity

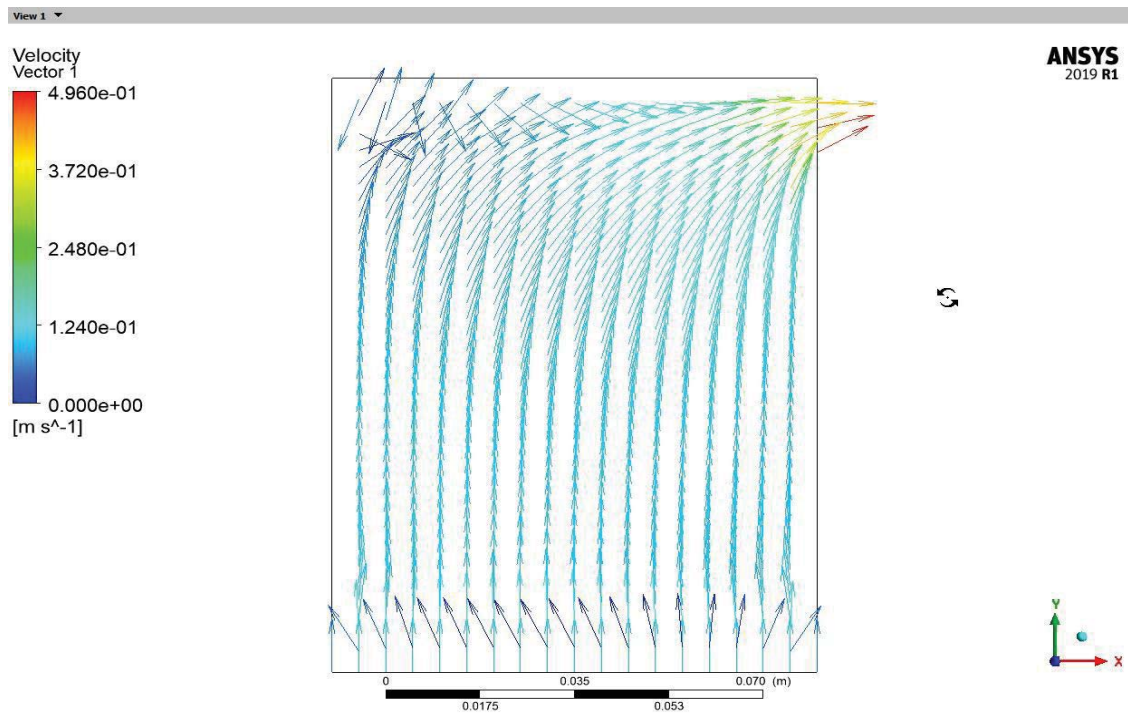

Fig-3.3.2.1.3 Velocity Vector

Result of Pressure

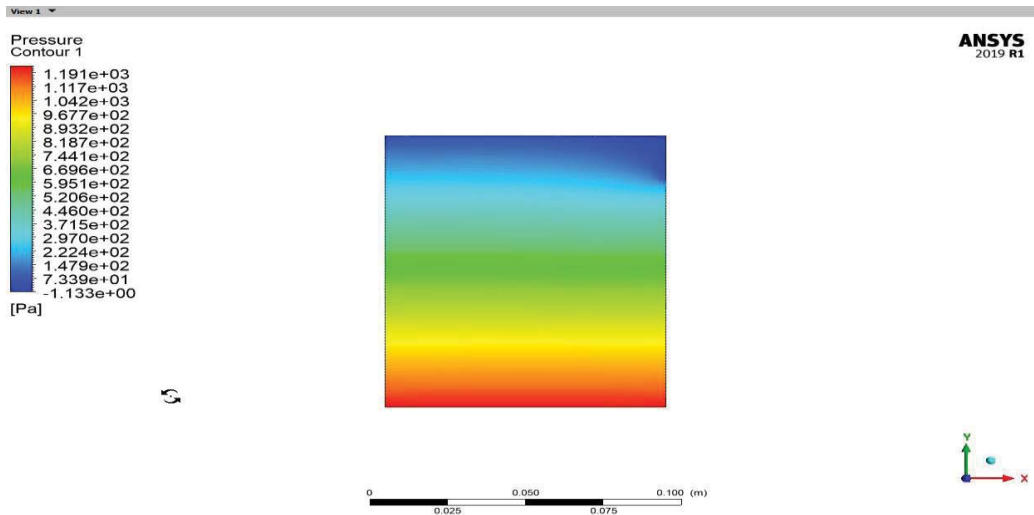

Fig-3.3.2.2.1 Pressure Result

- Calculation/Summary after run
 1. Mass flow rate at outlet= 8.98382 kg/sec (ideal condition)
 2. Maximum value of velocity of water at outlet= 0.513 m/sec
 3. Maximum pressure at wall-1= 122857 pa

CONCLUSION

Based on the experimental results obtained from the designed, fabricated and tested project a clear inference can be drawn that in old system for moving water for irrigation and drinking purpose from ground and river water to the required area are digging wells, making small channels from river to the require area, and using pump if the potential height is higher all such method are either fuel consuming or electricity and some are human effort. Our design does not require fuel or electricity and even it does not require human effort. It works on kinetic energy of flowing water. It has some Limitation but from the point of view of saving fuel electricity for small use our design it will be very helpful.



REFERENCES

- Mogaji P.B, “DEVELOPMENT OF AN IMPROVED PEDEL POWERED WATER PUMP”, International journal of scientific and engineering reasearch,2016,7,2.
- Arnaud landelle et al, “STUDY OF RECIPROCATING PUMP FOR SUPER CRITICAL ORC AT FULLAND PART LOAD OPERATION”,3rd international seminar on ORC power system,2015,1-8.
- Abhisakh mishra et al, “A REVIEW PAPER ON RECIPROCATING PUMP”, IJSRD, 2017, 5, 7
- Stavros I. Yannopoulos et al. “EVOLUTION OF WATER LIFTING DEVICES OVER THE CENTURIES WORLD WILD”, ISSN,2015,7,5032-5059
- Arnaudlandelleetal,“STUDY OF RECIPROCATING PUMP FOR SUPER CRITICAL ORC AT FULL AND PART LOAD OPERATION”, 3rd international seminar on ORC power system, 2015,1-8.
- Abhisakh mishra et al, “A REVIEW PAPER ON RECIPROCATING PUMP”, IJSRD, 2017,5,7
- StavrosI.Yannopoulosetal.“EVOLUTION OF WATER LIFTING DEVICES OVER THE CENTURIES WORLD WILD”, ISSN,2015,7,5032-5059